

---

## Operating instructions

---

### Cryogenic Globe valves

- Angle type -





**READ CAREFULLY BEFORE USE! RETAIN FOR FUTURE REFERENCE!**

**© 2019 HEROSE GMBH  
ARMATUREN UND METALLE**

Elly-Heuss-Knapp-Straße 12  
23843 Bad Oldesloe  
Germany

Phone: +49 4531 509 – 0

Fax: +49 4531 509 – 120

E-mail: [info@herose.com](mailto:info@herose.com)

Web: [www.herose.com](http://www.herose.com)

2<sup>nd</sup> issue 07/2019

The transmission or duplication of this document and the use or communication of its content are forbidden unless expressly permitted. Any violations shall result in liability for damages. All rights in the event of patent, utility model or registered design are reserved.

---

**Table of contents**

1	About these instructions .....	1
2	Safety .....	1
3	Transport and storage .....	4
4	Description of the angle valve .....	4
5	Assembly.....	7
6	Operation .....	10
7	Maintenance and service .....	11
8	Disassembly and disposal.....	13

# 1 About these instructions

## 1.1 Principles

The operating instructions are part of the angle valve named on the front page.



## 1.2 Applicable documents

Document	Contents
Catalogue page	Description of the angle valve

For accessories, refer to the respective manufacturer's documentation.

## 1.3 Hazard levels

The warning notes are marked and classified according to the following hazard levels:

Symbol	Explanation
 <b>DANGER</b>	Identifies a hazard with a high risk level that will result in death or serious injury.
 <b>WARNING</b>	Identifies a hazard with a moderate risk level that will result in death or serious injury.
 <b>CAUTION</b>	Identifies a hazard with a low risk level that will result in a minor or moderate injury.
<b>NOTICE</b>	Identifies a risk to property. Damage to property may occur if this notice is ignored.

# 2 Safety

## 2.1 Intended use

The angle valve is intended for mounting in a pipeline or pressure tank system in order to block media or allow them to pass through within the permissible operating conditions. The permissible operating conditions are specified in these operating instructions.

The angle valve is suitable for the media listed in these operating instructions; see section 4.5 "Media". Operating conditions and applications deviating from these require the approval of the manufacturer.

Only media may be employed to which the materials used for the valve body and seals are resistant. Contaminated media or usage outside of the pressure and temperature specifications can lead to damage to the valve body and seals.

### Avoidance of foreseeable incorrect use

- ▶ Never exceed the permissible usage limits specified in the data sheet or in the documentation with regard to pressure, temperature, etc.
- ▶ Follow all safety instructions and operating procedures in these operating instructions.

## 2.2 Meaning of the operating instructions

The operating instructions are to be read and followed by the responsible technical personnel before mounting and start-up. As part of the angle valve the operating instructions must be available close to it. People could be seriously injured or killed if the operating instructions are not followed.

- ▶ Read and observe the operating instructions before using the angle valve.
- ▶ Retain the operating instructions and make sure they are available.
- ▶ Pass on the operating instructions to subsequent users.

## 2.3 Requirements for persons who work with the angle valve

Persons could be seriously injured or killed if the angle valve is used improperly. In order to avoid accidents, all persons who work with the angle valve must meet the following minimum requirements.

- They are physically capable to control the angle valve.
- They can safely carry out the work with the angle valve within the scope of these operating instructions.
- They understand the operating principles of the angle valve within the scope of their work and are able to recognise and avoid the hazards of the work.
- They have understood the operating instructions and are able to implement the information of the operating instructions accordingly.

## 2.4 Personal protective equipment

Missing or unsuitable personal protective equipment increases the risk of damage to health and injuries to people.

- ▶ The following protective equipment is to be provided and worn during work:
  - Protective clothing
  - Safety shoes
- ▶ Define and use additional protective equipment depending on the application and the media:
  - Safety gloves
  - Eye protection
  - Ear protection
- ▶ Wear the specified personal protective equipment for all work on the angle valve.

## 2.5 Additional equipment and spare parts

Additional equipment and spare parts not conforming to the manufacturer's requirements can negatively affect the operational safety of the angle valve and cause accidents.

- ▶ In order to ensure operational safety, use original parts or parts that conform to the manufacturer's requirements. If in doubt, have these confirmed by the dealer or manufacturer.

## 2.6 Adhere to the technical thresholds

If the technical threshold values are not adhered to, the angle valve may sustain damage, accidents may be caused and people may be seriously injured or killed.

- ▶ Adhere to the thresholds. See section "4 Description of the angle valve".

## 2.7 Safety instructions

### **DANGER**

#### **Hazardous medium.**

Escaping operating medium can lead to poisoning, burns and caustic burns!

- ▶ Wear the prescribed protective equipment.
- ▶ Provide suitable collecting containers.

### **WARNING**

#### **Harmful and/or hot/cold conveyed media, lubricants and fuels.**

Hazardous for persons and the environment!

- ▶ Collect and dispose of rinsing medium and any residual media.
- ▶ Wear protective clothing and a protective mask.
- ▶ Observe legal regulations regarding the disposal of harmful media.

#### **Risk of injury if maintenance work is done incorrectly.**

Incorrect maintenance can lead to serious injury and considerable material damage!

- ▶ Before the start of work, ensure there is sufficient room for doing the work.
- ▶ Ensure the space around the work is tidy and clean! Parts and tools in loose piles or lying around are hazard sources.
- ▶ If parts have been removed, take care to assemble correctly and re-install all attachment items.
- ▶ Before putting back into service, ensure:
  - All maintenance work has been carried out and completed.
  - There are no persons in the hazard area.
  - All covers and safety devices are installed and operating correctly.

## CAUTION

### **Cold/hot pipelines and/or angle valves.**

Risk of injury due to thermal influences!

- ▶ Insulate the angle valve.
- ▶ Attach warning signs.

### **Medium escaping at high speed and high/low temperature.**

Risk of injury!

- ▶ Wear the prescribed protective equipment.

## NOTICE

### **Impermissible stresses arising from operating conditions and extensions / added structures.**

Angle valve body leaking or broken!

- ▶ Provide suitable support.
- ▶ Additional loads, such as traffic, wind or earthquakes, are not explicitly taken into account by default and require separate sizing.

### **Condensation in air conditioning, cooling and refrigeration plants.**

Icing!

Blocking of the actuation mechanism!

Damage due to corrosion!

- ▶ Insulate the angle valve with diffusion-tight material.

### **Improper handling.**

Leak or damage to the angle valve!

- ▶ Do not store tools and/or other objects on the angle valve.
- ▶ Do not use tools to increase the torque of the hand wheel.

### **Painting of the angle valve and pipelines.**

Functional impairment of the valve / loss of information!

- ▶ Protect stem, plastic parts and type plate against the application of paint.

### **Impermissible stress**

Damage to the control mechanism!

- ▶ Do not use the angle valve as a foothold.

### **Exceeding the maximum permissible operating conditions.**

Damage to the angle valve!

- ▶ The maximum permissible operating pressure must not be exceeded, and the minimum and maximum allowable working temperatures must be observed.
- ▶ Create the welding/soldering seam stepwise so that the warming in the middle of the body does not exceed the maximum permissible operating temperature.

### **Welding beads, scale and other contaminants.**

Damage to the angle valve!

- ▶ Take appropriate measures against contamination.
- ▶ Remove contaminants from the pipes.

### **Incorrect earthing during welding work in the pipeline.**

Damage to the angle valve (burned spots)!

- ▶ Remove bonnet during welding.
- ▶ When carrying out electric welding work, do not use functional parts of the angle valve for earthing.

### 3 Transport and storage

#### 3.1 Inspection of condition on delivery

- ▶ Inspect the angle valve for damage upon receipt.  
In case of transport damage, determine and document the precise extent of the damage, and report it immediately to the supplying dealer/carrier and the insurer.

#### 3.2 Transportation

- ▶ Transport the angle valve in the packaging supplied.  
The angle valve is delivered ready to operate with lateral connections protected by cover caps.
- ▶ Protect the angle valve against hammering, impacts, vibrations and dirt.
- ▶ Adhere to a transport temperature range of -20 °C to +65 °C.

#### 3.3 Storage

- ▶ Store the angle valve in a clean and dry place.
- ▶ Make use of a desiccant or heating in damp storerooms to prevent the formation of condensation.
- ▶ Adhere to a storage temperature range of -20 °C to +65 °C.

### 4 Description of the angle valve

Refer to the respective catalogue page for further detailed information.

#### 4.1 Structure



##### Design

Non-automatically opening and closing gate valve angle type.

Component	Design
Body	Angle type
Bonnet	Flanged, internal spindle thread
Operating mechanism	Rising stem
Obturator	Disc with seal made of non-metallic materials
Stem bushing	Non self-sealing, packing gland
Body end	with soldering end with welding end with threaded end (G; R; NPT; M) with welded-in/soldered-in pipes

#### 4.2 Valving marking

The angle valves are provided with an individual marking for identification.

Symbol	Explanation
DN.....	Nominal diameter
PN.....	Rated working pressure (max. permissible operating pressure)
-.....°C +.....°C	Temperature
	Manufacturer's mark "HEROSE"
01/18	Year of construction MM/YY
12345	Type
01234567	Serial no.
EN1626	Standard
 0045	CE-mark and number of the notified body
 0045	PI-mark and number of the notified body
e.g. CF8 / 1.4308	Material



### 4.3 Intended use

Angle valves are used for shutting off and/or throttling media.

Install angle valves so that the stem is vertical and the type of the medium enters under the cone.

The angle valve is opened or closed by turning the handwheel or actuating the actuator. Tools for increasing handwheel torque are not allowed.

Detailed installation instructions for the actuator are included for angle valves with pneumatic or electric actuator-unit.

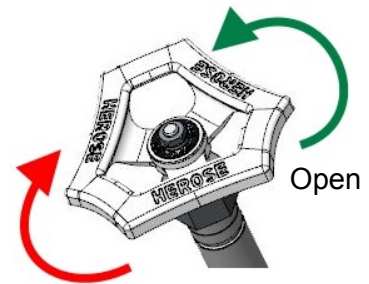

### 4.4 Operational data

Valve	Nominal pressure	Permissible operating temperature	Recommended operating temperature	Max. operating pressure
01312	PN50	-196 °C to +120 °C	-	50 bar
01322	PN50	-196 °C to +120 °C	-	50 bar
01332	PN50	-196 °C to +120 °C	-60 °C to +120 °C	50 bar
01342	PN50	-196 °C to +120 °C	-	50 bar
01346	PN50	-196 °C to +120 °C	-	50 bar
01352	PN50	-196 °C to +120 °C	-60 °C to +120 °C	50 bar

### 4.5 Media

Gases, cryogenic liquefied gases and their gas mixtures, such as:

Name
Argon,
Chlorotrifluoromethane,
Nitrous oxide,
Ethane,
Ethylene,
Carbon dioxide,
Carbon monoxide
Krypton,
LNG
LPG
Methane,
Oxygen,
Nitrogen,
Trifluoromethane,

## 4.6 Materials

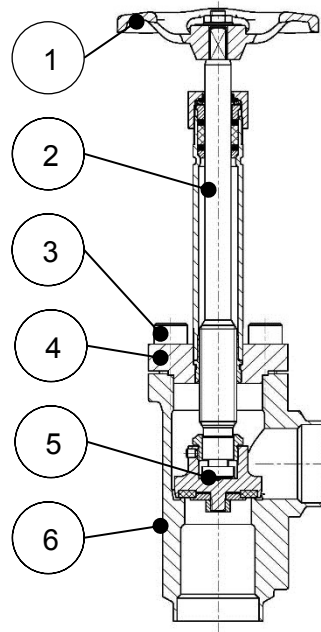

Part no.	Name	Material
1	Handwheel	Aluminium alloy
2	Stem	1.4301; 1.4305
3	Screws	A2 – 70
4	Bonnet	CC493K; 1.4301; 1.4308
5	Obturator	CW614N; 1.4301; Hostafion TF4215; TFM 1600; TFM 1700
6	Body	1.4308 (CF8); CC491K

## 4.7 Scope of delivery

- Valve
- Operating instructions

## 4.8 Dimensions and weights

- ▶ See catalogue page.

## 4.9 Lifetime

The user is obligated to use Herose products only for their intended purpose.

In this case, a technical service life may be assumed in accordance with the underlying product standards (e.g. EN1626 for shut-off valves and EN ISO 4126-1 for safety valves).

The technical service life can be restarted several times through the exchange of wearing parts within the context of the maintenance intervals, and lifetimes of more than 10 years can be achieved.

If products are stored for a period exceeding 3 years, then the plastic components and elastomer sealing elements fitted to the product should be replaced as a precautionary measure before mounting and use.

## 5 Assembly

### 5.1 Installation position

With regard to the installation position, pay attention to the arrow showing the flow direction. When installing the angle valve in a horizontal pipeline, a vertical position of the stem is recommended (handwheel at the top) or an inclination of up to 65° from the vertical.



### 5.2 Notices regarding the mounting

- ▶ Use suitable tools.
  - Allen keys of sizes 6, 8 and 10;
  - Open-ended spanners;
  - Torque wrench;
  - TIG welding machine;
  - Oxy-fuel welding machine;
- ▶ Clean tools before the mounting.
- ▶ Use suitable transport and lifting equipment for the mounting.
- ▶ Open the packaging only directly before the mounting. Free from oil and grease for oxygen (O<sub>2</sub>)  
Angle valves for oxygen are permanently labelled with "O<sub>2</sub>".
- ▶ Only install the angle valve if the maximum operating pressure and operating conditions of the plant correspond to the marking on the valve.
- ▶ Remove protective caps or covers before mounting.
- ▶ Check the angle valve for dirt and damage.  
DO NOT install a damaged or dirty angle valve.
- ▶ Avoid damaging the connections.  
The sealing surfaces must remain clean and intact.
- ▶ Seal the angle valve with suitable seals.  
No sealant (sealing tape, liquid sealing tape) may enter the angle valves.  
Respect the suitability for use with O<sub>2</sub>.
- ▶ Connect pipelines in a force-free and torque-free manner.  
Stress-free mounting.
- ▶ In order to ensure trouble-free operation, no impermissible static, thermal or dynamic stresses may be transmitted to the angle valve. Observe reaction forces.
- ▶ Temperature-dependent changes in length in the pipework system must be compensated with expansion joints.
- ▶ The angle valve is supported by the pipework system.
- ▶ Detailed installation instructions are included for angle valves with pneumatic or electric actuator-unit.
- ▶ Driven angle valves: Mounting/dismounting the bonnet in the centre position of the actuator.
- ▶ The angle valve must be protected against dirt and damage during construction work.
- ▶ Remove any transport locks such as blocking bushing (optional).
- ▶ Check the leak-tightness.



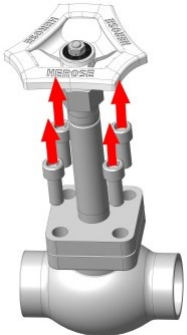
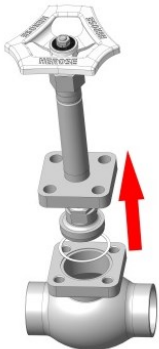

### 5.3 Welding / soldering

Welding / soldering of the angle valves and any heat treatment that may be required are the responsibility of the contracting construction company or operating company.

■ Before welding / soldering

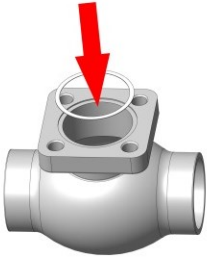
	<ul style="list-style-type: none"> <li>▶ Loosen the screws Direction of rotation: counter clockwise</li> </ul>
	<ul style="list-style-type: none"> <li>▶ Remove the screws</li> </ul>
	<ul style="list-style-type: none"> <li>▶ Remove bonnet and seal</li> </ul>
	<ul style="list-style-type: none"> <li>▶ Dispose of the seal</li> </ul>
	<ul style="list-style-type: none"> <li>▶ Weld / solder in the body</li> </ul>

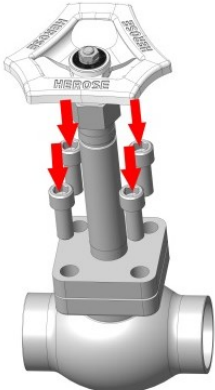
■ After welding / soldering

	<p>▶ Insert a new seal</p>
	<p>▶ Assemble the bonnet              ⚠ Do not damage the seal</p>
	<p>▶ Assemble the screws</p>
	<p>▶ Tighten the screws to the specified tightening torque in a criss-cross pattern              Direction of rotation: clockwise</p>

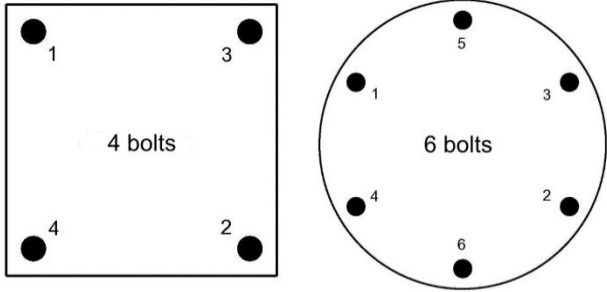

► Assembly sequence for the bolts

Nominal diameter	Gun-metal-bonnet/ Gun-metal-body [Nm]	Gun-metal-bonnet/ VA-body [Nm]		VA-bonnet/ VA-body [Nm]	Cap bolt
DN 10	19	19	25	30	M8
DN 15	19	19	25	30	M8
DN 20	37	44		50	M10
DN 25	37	44		50	M10
DN 32	41	45		50	M10
DN 40	51	60		70	M12
DN 50	49	50		50	M10



► Check the leak-tightness

## 6 Operation

### 6.1 Prior to start-up

- Check the following points prior to start-up:
  - All mounting and installation work are completed.
  - If fitted: The blocking bushing was removed prior to start-up.
  - The safety guards are in place.
  - Compare the material, pressure, temperature and installation position with the layout plan for the pipework system.
  - Dirt and residues have been removed from the pipeline and valve in order to prevent leaks.

## 7 Maintenance and service

### 7.1 Safety during cleaning

- ▶ Take note of the specifications in the safety data sheet and the general occupational health and safety rules if degreasers are used for process-related reasons for the cleaning of bearing parts, unions and other precision parts.

### 7.2 Maintenance

The maintenance intervals must be defined by the user according to the operating conditions.

The recommendations for the functional checking of the angle valves are to be taken from section 7.2.1 "Inspection and maintenance intervals" in these operating instructions.

#### 7.2.1 Inspection and maintenance intervals

Recommended intervals		
Description	Interval	Scope
Inspection	▶ During start-up	<ul style="list-style-type: none"> <li>■ Visual inspection                             <ul style="list-style-type: none"> <li><input type="checkbox"/> of the angle valve for damage;</li> <li><input type="checkbox"/> of the valving marking for legibility;</li> <li><input type="checkbox"/> Installation position;</li> </ul> </li> <li>■ Leak-tightness                             <ul style="list-style-type: none"> <li><input type="checkbox"/> at the gland packing;</li> <li><input type="checkbox"/> between bonnet and body;</li> <li><input type="checkbox"/> of the valve seat;</li> </ul> </li> <li>■ Test the opening and closing functions of the angle valve.</li> </ul>
Functional testing	▶ Annually	<ul style="list-style-type: none"> <li>■ Test the opening and closing functions of the angle valve including a visual inspection.</li> </ul>
External inspection	▶ Every 2 years	<ul style="list-style-type: none"> <li>■ Function and tightness test including visual check.</li> </ul>
Internal inspection	▶ Every 5 years	<ul style="list-style-type: none"> <li>■ Replacement of all sealing elements, including a function and tightness test as well as a visual inspection.</li> </ul>
Hydraulic testing	▶ Every 10 years	<ul style="list-style-type: none"> <li>■ Replacement of all sealing elements, including a function, leak and pressure test as well as an inspection.</li> </ul>

### 7.3 Fault table

Fault	Cause	Remedial action
<ul style="list-style-type: none"> <li>Leak at the stem</li> </ul>	Gland nut loose	▶ Retighten the gland nut
	Gland packing defective	▶ Replace the gland packing
	Fit on the stem damaged	▶ Replace the stem
<ul style="list-style-type: none"> <li>Leak between bonnet and body</li> </ul>	Bonnet loose	▶ Tighten the screws to the specified tightening torque
	Seal damaged	▶ Replace seal
<ul style="list-style-type: none"> <li>Leak in the seating</li> </ul>	Foreign body between cone and seating	▶ Remove foreign body / flush the system
	Seating damaged	▶ Replace the body
	Cone seal damaged	▶ Replace the cone
<ul style="list-style-type: none"> <li>Body leaking</li> </ul>	Discontinuity/gas cavity open	▶ Replace the body
<ul style="list-style-type: none"> <li>Angle valve does not open / close</li> </ul>	Gland nut overtightened	▶ Loosen the gland nut Tightness must still be ensured
	Thread seized	▶ Replace bonnet
	Actuator not working	▶ Check supply of energy to the actuator ▶ Check limit switches

### 7.4 Spare parts

We require the following details for your spare part orders:

- article no. of the spare part package,
- desired delivery quantity,
- dispatch and delivery address,
- desired method of dispatch.

### 7.5 Returns / complaints

Use the Service form in case of returns/complaints.



Contact in case of service:  
 Herose.com › Service › Product service › Complaints  
 E-mail: [service@herose.com](mailto:service@herose.com)  
 Fax: +49 4531 509 – 9285



## **8 Disassembly and disposal**

### **8.1 Notices regarding the disassembly**

- ▶ Take note of all national and local safety requirements.
- ▶ The pipework system must be depressurised.
- ▶ The medium and valve must be at ambient temperature.
- ▶ Aerate / flush the pipework system in the case of corrosive and aggressive media.

### **8.2 Disposal**

1. Dismount the valves.
  - ▶ Collect greases and lubricating fluids during dismantling.
2. Separate the valve materials:
  - Metal
  - Synthetic material
  - Electronic scrap
  - Greases and lubricating fluids
3. Carry out a sorted disposal of the materials.

